

August 2014

MARINE AUXILIARY EQUIPMENTS

Oryx Energies range of Sealub Alliance lubricants



Part of AOG

MARINE AUXILIARY EQUIPMENTS



Oryx Energies, headquartered in Switzerland, enjoys exclusive rights for production and distribution of Sealub Alliance marine lubricants products and services in Eastern and Western Africa, including Benin, Senegal, Côte d'Ivoire, Togo, Ghana, Nigeria, South Africa, Kenya, Tanzania and Mozambique. This partnership grants Oryx Energies a direct access to the network's products and services in more than 850 ports in 75 countries within the Sealub Alliance Network.

Oryx Energies and Gulf Oil Marine, as partners in the Alliance, aim at providing the most expert assistance to their customers, through extensive geographical coverage, delivery knowledge, supply reliability, customer service and technical support.

Oryx Energies' expertise in international trade and strong knowledge of the African continent for over 25 years provides the Alliance and its own customers with a first class logistical services and a very well implanted organization in sub-Saharan Africa.

Oryx Energies offers a full range of products and services to domestic, industrial and marine customers: distribution, storage, logistics, petroleum products supplies, service stations, bitumen, LPG, bunker fuel, lubricants and lubrication services. The company offers storage capacity in excess of 600,000 cubic meters, a network of more than 100 service stations and high quality lubricants manufactured in our two plants located in Lomé (Togo) and Dar Es Salaam (Tanzania).



Sealub Alliance and Oryx Energies Lubricants Typical Values

LUBRICANTS	SAE or ISO	BN	DENSITY		VISCOSITY (mm ² /S) @100°C	POUR POINT (°C)	FLASH POINT COC (°C)	APPLICATION
			15°C	20°C				

SYSTEM OIL

OrSea SuperBear 3008	30	8	0.886	0.883	11.2	-18	232	Marine Engine Crankcase Oil specially designed for modern Low Speed 2-stroke Marine Main Engines using Heavy Fuel Oil (HFO)
OrSea SuperBear 4008	40	8	0.889	0.886	14.2	-18	240	Marine Engine Crankcase Oil specially designed for modern Low Speed 2-stroke Marine Main Engines using Heavy Fuel Oil (HFO)

CYLINDER OILS

OrSea Cylcare DCA 5040H	50	40	0.992	0.919	18.3	-18	242	Marine Cylinder Oil specially designed for modern Low Speed 2-stroke Marine Main Engines using Heavy Fuel Oil (HFO)
OrSea Cylcare DCA 5070H	50	70	0.934	0.931	18.5	-18	246	Marine Cylinder Oil specially designed for modern Low Speed 2-stroke Marine Main Engines using Heavy Fuel Oil (HFO)

TRUNK PISTON ENGINE OILS

OrSea Power MDO 3012	30	12	0.892	0.889	11.1	-18	232	Marine Diesel Engine Oil specially designed for all types of modern High or Medium Speed 4-stroke Diesel Engines running Gas Oil or Marine Diesel Oil (MDO)
OrSea Power MDO 3015	30	15	0.894	0.891	11.2	-18	232	Marine Diesel Engine Oil specially designed for all types of modern High or Medium Speed 4-stroke Diesel Engines running Gas Oil or Marine Diesel Oil (MDO)
OrSea Power MDO 3020	30	20	0.890	0.887	11.2	-18	232	Marine Diesel Engine Oil specially designed for all types of modern High or Medium Speed 4-stroke Diesel Engines running Gas Oil or Marine Diesel Oil (MDO)
OrSea Power MDO 4012	40	12	0.895	0.892	14.1	-18	240	Marine Diesel Engine Oil specially designed for all types of modern High or Medium Speed 4-stroke Diesel Engines running Gas Oil or Marine Diesel Oil (MDO)
OrSea Power MDO 4015	40	15	0.897	0.894	14.3	-18	244	Marine Diesel Engine Oil specially designed for all types of modern High or Medium Speed 4-stroke Diesel Engines running Gas Oil or Marine Diesel Oil (MDO)
OrSea Power MDO 4020	40	20	0.900	0.897	14.2	-18	242	Marine Diesel Engine Oil specially designed for all types of modern High or Medium Speed 4-stroke Diesel Engines running Gas Oil or Marine Diesel Oil (MDO)



Sealub Alliance and Oryx Energies Lubricants Typical Values

LUBRICANTS	SAE or ISO	BN	DENSITY		VISCOSITY (mm ² /S) @100°C	POUR POINT (°C)	FLASH POINT COC (°C)	APPLICATION
			15°C	20°C				

TRUNK PISTON ENGINE OILS - CONTINUED

OrSea Power 3030	30	30	0.900	0.897	11.1	-18	228	Marine Trunk Piston Engine Oil specially designed for modern Medium Speed 4-stroke Marine Engines running Intermediate Fuel Oil (IFO) or Heavy Fuel Oil (HFO)
OrSea Power 3040	30	40	0.910	0.907	11.3	-18	234	Marine Trunk Piston Engine Oil specially designed for modern Medium Speed 4-stroke Marine Engines running Intermediate Fuel Oil (IFO) or Heavy Fuel Oil (HFO)
OrSea Power 3055	30	55	0.950	0.947	11.0	-18	232	Marine Trunk Piston Engine Oil specially designed for modern Medium Speed 4-stroke Marine Engines running Intermediate Fuel Oil (IFO) or Heavy Fuel Oil (HFO)
OrSea Power 4030	40	30	0.900	0.897	14.2	-18	244	Marine Trunk Piston Engine Oil specially designed for modern Medium Speed 4-stroke Marine Engines running Intermediate Fuel Oil (IFO) or Heavy Fuel Oil (HFO)
OrSea Power 4040	40	40	0.910	0.907	14.3	-18	246	Marine Trunk Piston Engine Oil specially designed for modern Medium Speed 4-stroke Marine Engines running Intermediate Fuel Oil (IFO) or Heavy Fuel Oil (HFO)
OrSea Power 4055	40	55	0.920	0.917	14.2	-18	242	Marine Trunk Piston Engine Oil specially designed for modern Medium Speed 4-stroke Marine Engines running Intermediate Fuel Oil (IFO) or Heavy Fuel Oil (HFO)

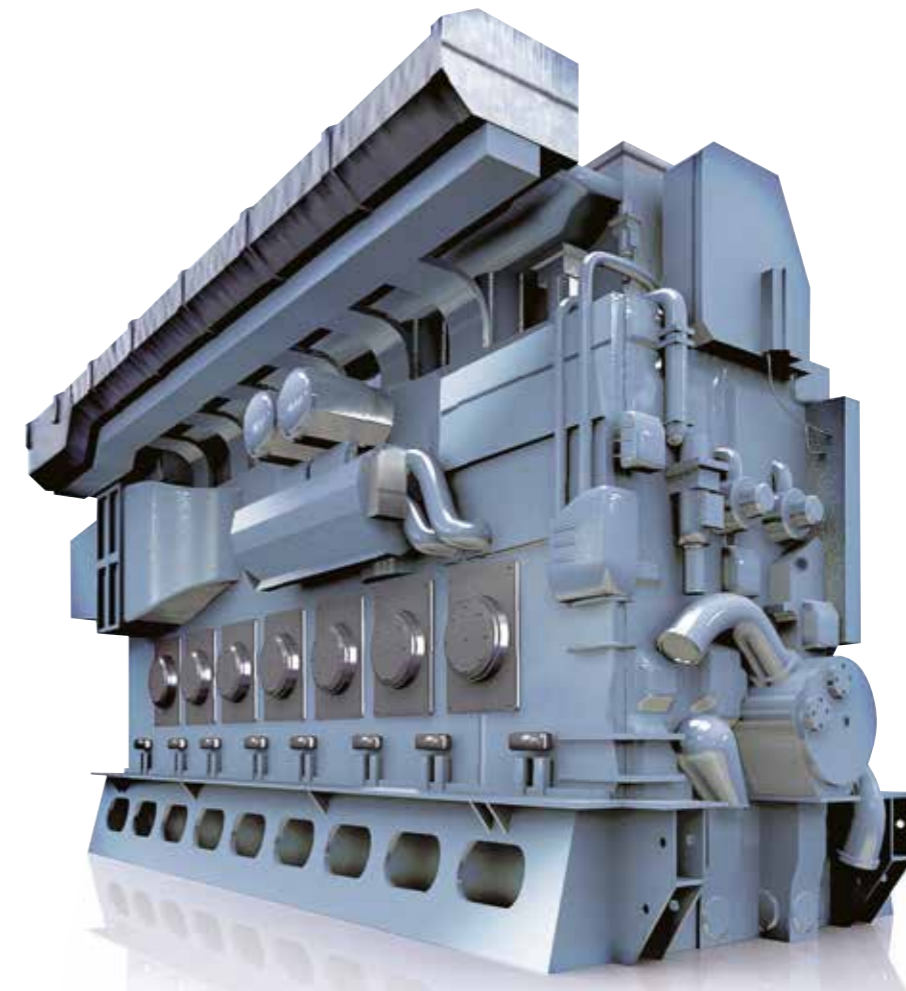

ORSEA POWER

PRODUCT CHARACTERISTICS

- **OrSea Power** is a premium quality multifunctional trunk piston engine oil designed to be used in the most modern medium speed trunk piston 4-stroke diesel engines operating on residual marine fuels
- **OrSea Power** has been specifically formulated to offer a **comfortable safety margin** to cover the increasing technical demands of these engines operating on widely **varying fuel qualities**. Its advanced sludge control additive technology perfectly meets these requirements and also provides exceptional engine **cleanliness** and **wear protection**
- **OrSea Power** is available in SAE 30 & 40 viscosity grades with a TBN (Total Base Number) ranging from 30 to 55

“Exceptional detergency reduces build-up of soot & black sludge”

“Excellent anti-wear properties guarantee the engine protection”

APPLICATIONS

- **OrSea Power** is recommended for modern medium speed marine engines used on board ships and also in power generation plants which operate on residual fuels
- **OrSea Power 3055 & 4055** are specifically formulated for the modern low consumption engines fitted with ‘anti polishing’, ‘flame’ or ‘fire’ rings that operate on very high sulphur residual fuels. These marine lubes are also specially recommended for 4-stroke ship engines where the marine lube has to stay in use for extended time periods and when a less frequent oil top-up is required
- **OrSea Power 3040 & 4040** are adequate for the most modern and lower lube oil consuming engines operating on residual fuels and having sulphur content in excess of 3.5%
- **OrSea Power 3030 & 4030** are suitable for the modern engines operating on residual fuels having sulphur content in the range of 2.5% to 3.5%

TECHNICAL PROPERTIES

- **Exceptional detergency capabilities** that reduce the build-up of soot & black sludge and improve the tolerance to heavy fuel contaminants
- **Superior quality of the additive package** which ensures leading performance while burning various qualities of marine fuels, and which maintains an optimal level of engine cleanliness
- **Premium high base number additive property** that ensures quick and efficient neutralization of acidic attacks, thus guaranteeing the engine protection from corrosive wear
- **Superior demulsibility properties** that ensure rapid water separation leading to easy filtration and also contaminant elimination, therefore allowing trouble-free operation
- **Robust anti-wear technology** provides excellent piston & linear wear control and good gear performance leading to a reduction in maintenance costs
- **Excellent thermo-oxidative stability** retards BN depletion trend hence extends the lubricant performance duration postponing the need for top-up and allowing significant savings to the consumer

DETERGENCY

ANTI CORROSION

ANTI-OXIDATION

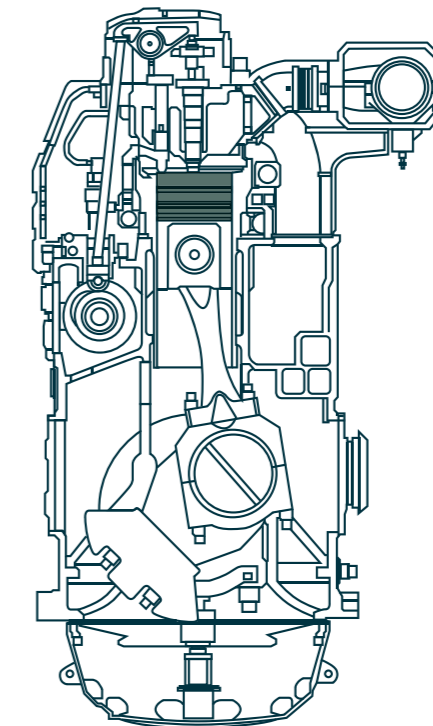

DEMULSIBILITY - FILTRABILITY

EXTREME PRESSURE ANTI-WEAR

THERMAL STABILITY

FEATURES & BENEFITS



Thermo-oxidative stability and excellent anti-wear properties guarantee the engine protection and allow extended marine lubricant life and significant savings for the engine operator



Additive package's superior performance ensures leading performance and safety margin and allows the operator to burn marine fuel of a wide range of quality levels



Superior demulsibility properties ensure easy water separation and filtration of contaminants



Strong anti-wear properties enable excellent piston & linear wear control

ORSEA POWER MDO

PRODUCT CHARACTERISTICS

- **OrSea Power MDO** is a premium quality trunk piston engine lubricant designed to be used in medium speed 4-stroke diesel engines operating on distillate fuels or marine diesel fuels
- Its formulation uses most modern additive technology and its properties contribute to the **engine superior cleanliness & protection**. **OrSea Power MDO** extended life properties will also contribute to a better engine condition and monitoring thus leading to cost savings
- **OrSea Power MDO** is available in SAE 30 & 40 viscosity grades with a TBN (Total Base Number) ranging from 12 to 20

“Superior detergency ensures piston and crankcase cleanliness”

APPLICATIONS

- **OrSea Power MDO** is recommended for medium speed engines used in marine and power generation operating on distillate fuels and/or marine diesel fuels. It is specially recommended for older engines where liner-lacquer is not a potential problem. OrSea Power MDO is formulated for the lubrication of 4-stroke main propulsion vessels engines as well as power generation engines or vessels' auxiliary engines
- **OrSea Power MDO 3012 & 4012** have a TBN of 12 and are adequate for the engines operating solely on distillate fuels with a sulphur content below 1%
- **OrSea Power MDO 3015 & 4015** are suitable for the modern engines operating on distillate fuels or marine diesel fuels with a sulphur content less than 1.5%
- **OrSea Power MDO 3020 & 4020** are recommended for the modern engines operating on distillate fuels or marine diesel fuels with a sulphur content up to 2%
- **OrSea Power MDO** is also recommended for general lubrication of shipboard equipment where more specifically formulated lubricants are not required and where a SAE 30 or SAE 40 viscosity is recommended



RECOMMENDED FOR DEEP SEA FISHING VESSELS

- **OrSea Power MDO** is specially recommended for 4-stroke engines Open Water fishing vessels operating on distillate fuels or marine diesel fuels, which engine load change frequently (full speed & idle running)
- **OrSea Power MDO** brings extended performance and flexibility for these Deep Sea fishing vessels engines that require precise & quick maneuverability, full speed keeping for long periods and low speed loading for long periods too

TECHNICAL PROPERTIES

- **Superior detergency properties** ensure optimal piston and crankcase cleanliness
- **Improved anti-wear properties** provide excellent engine wear control and good performance leading to a reduction in maintenance costs
- **Excellent thermo-oxidative stability** retards BN depletion and allows for extended retention of correct viscosity, leading to significant costs savings
- The alkaline additive reserves provide a safety margin that **prevents the engine parts from attack by corrosive combustion** products and guarantees the smooth operation of the engine
- **Good demulsibility** characteristics ensure water separation and lead to trouble free operation
- **Special rust & corrosion inhibitors** prevent corrosion of engine parts

DETERGENCY

EXTREME PRESSURE ANTI-WEAR

THERMAL STABILITY

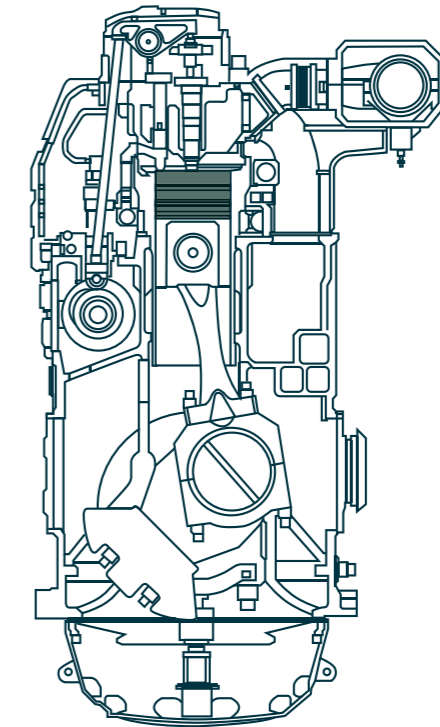

ANTI CORROSION

DEMULSIBILITY - FILTRABILITY

BASE NUMBER

FEATURES & BENEFITS



Superior formulation detergency maintains the engine cleanliness . The base number indicates the level of alkalinity reserves available to ensure a good safety margin for engine protection from corrosive wear, with distillate fuels containing up to 2% sulphur. Excellent anti-oxidation properties provides engine protection against piston, cylinder and bearing wear



Savings – Long-life Lubricant
Anti-wear properties associated with BN depletion slow down properties enables **OrSea Power MDO** to perform longer without topping up, guaranteeing maintenance significant savings

ORSEA CYLCARE DCA 5070H

PRODUCT CHARACTERISTICS

OrSea Cylcare DCA 5070H is a superior quality marine cylinder lubricant designed for all low speed 2-stroke engines operating on residual marine fuels. This marine lube is specially developed for main engines operating at high cylinder pressures & temperatures and long piston strokes. It has an outstanding quick capability to neutralize acid action thus minimizing the liner and ring wear and helping to prolong the life of engine components. The other main characteristic of this lube is its superior detergency that minimizes the deposits on the engine critical parts like the pistons, piston rings, ring grooves and cylinder ports.

OrSea Cylcare DCA 5070H provides excellent engine cleanliness and an outstanding contribution to 2-stroke marine engines durability.

This marine lube is available in SAE 50 viscosity grades and has a TBN (Total Base Number) of 70.

APPROVALS

«**DCA 5070H**» is a specifically designed lubrication technology and the additive package has passed successfully full in-house laboratory tests and extensive engine field tests that confirm its premium performance.

CYLCARE DCA is also available for low speed cross head engines operating on low sulphur heavy fuel oil with a sulphur content of maximum 1.5%. **CYLCARE DCA 5040H** is a SAE 50 TBN 40.

TECHNICAL PROPERTIES



Specific formulation

Rapidly neutralize the acidic by-products formed during the combustion of high sulphur fuels and thus protects the ring pack from wear



Enhanced detergency and dispersancy

Minimize the deposits on the engines' most important parts and maintains the cleanliness of piston lands, grooves and scavenge ports



Anti wear properties and strong oil film

Guarantee, even at the highest cylinder pressure, the protection of engine components against wear and scuffing

- Excellent Thermal Stability even under high temperature operating conditions, maintains the ring pack in very good condition
- Formulation designed and proven to cope with the toughest utilization conditions of the most recent 2-stroke engines : high pressures, highest temperatures and all-year long use.
- Good compatibility with all normal seal materials

APPLICATIONS

- OrSea Cylcare DCA 5070H is recommended for the cylinder lubrication of all, and particularly the most recent, low speed crosshead 2-stroke marine diesel engines operating on residual marine fuels with sulphur contents in excess of 1%
- While using OrSea Cylcare DCA 5070H, the feed rates the manufacturer recommends can be kept to the minimum. In certain circumstances, depending on the engine and operation conditions, higher feed rates may be required

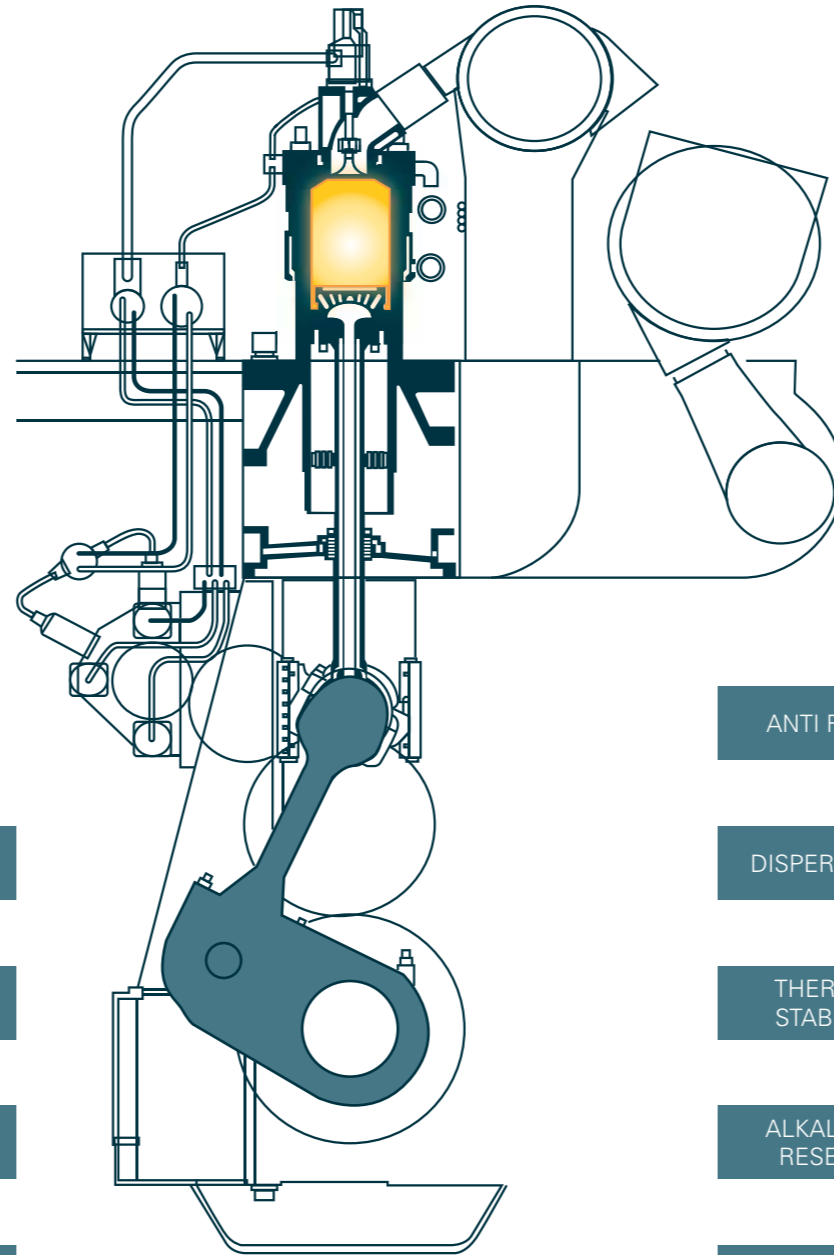

THERMAL STABILITY

DETERGENCY

ANTI OXIDATION

DISPERSANCY

ANTI SCUFFING

COMPATIBILITY

ALKALINITY RESERVE

ANTI FOAM

DISPERSANCY

THERMAL STABILITY

ALKALINITY RESERVE

ANTI CORROSION

ANTI OXIDATION

DEMULSIBILITY

DETERGENCY

ORSEA SUPERBEAR

PRODUCT CHARACTERISTICS

OrSea Superbear Series are premium quality system lubricants designed for all the latest design, high-output crosshead marine engines, particularly those running under severe operating conditions. These lubricants are formulated from high quality paraffinic base oils together with very modern additive package technology to provide **OrSea Superbear Series** with superior thermal stability and excellent resistance to oxidation. **OrSea Superbear Series** have ideal properties to cool the piston undercrown and to ensure lubrication of the bearings. Moreover, their alkalinity properties will adequately neutralise any strong acids which may enter into the crankcase.

OrSea Superbear Series are available in SAE 30 & SAE 40 viscosity grades with a TBN (Total Base Number) of 8.

APPROVALS

«**Superbear Series**» are specifically designed lubricant formulation technology and their additive package has successfully passed full in-house laboratory tests and extensive engine field tests that confirmed its premium performance.

TECHNICAL PROPERTIES



Excellent thermal stability

Maintains the oil at its top condition as it cools the pistons



Superior detergency properties

Maintains a high degree of cleanliness in the crankcase



Premium quality of the additive package alkalinity

Guarantees a rapid neutralization of acids formed by fuel combustion which might enter the crankcase



Specific anti-rust and anti-wear properties

Protect critical bearing surfaces from corrosion and damage, and thus extend the life of these engine parts



Specific formulation

Retards oil degradation thus ensuring long and trouble free service

APPLICATIONS

Recommended for the crankcase lubrication of the latest 2-stroke crosshead marine engines, even those with the highest specific power rating

Oryx Energies SA (Head Office)
12, rue Michel-Servet - P.O. Box 404
CH-1211 Geneva 12 - Switzerland
Tel: +41 58 702 90 00 - Fax: +41 58 702 90 25
info@oryxenergies.com
www.oryxenergies.com

